

**MiMA**<sup>®</sup>

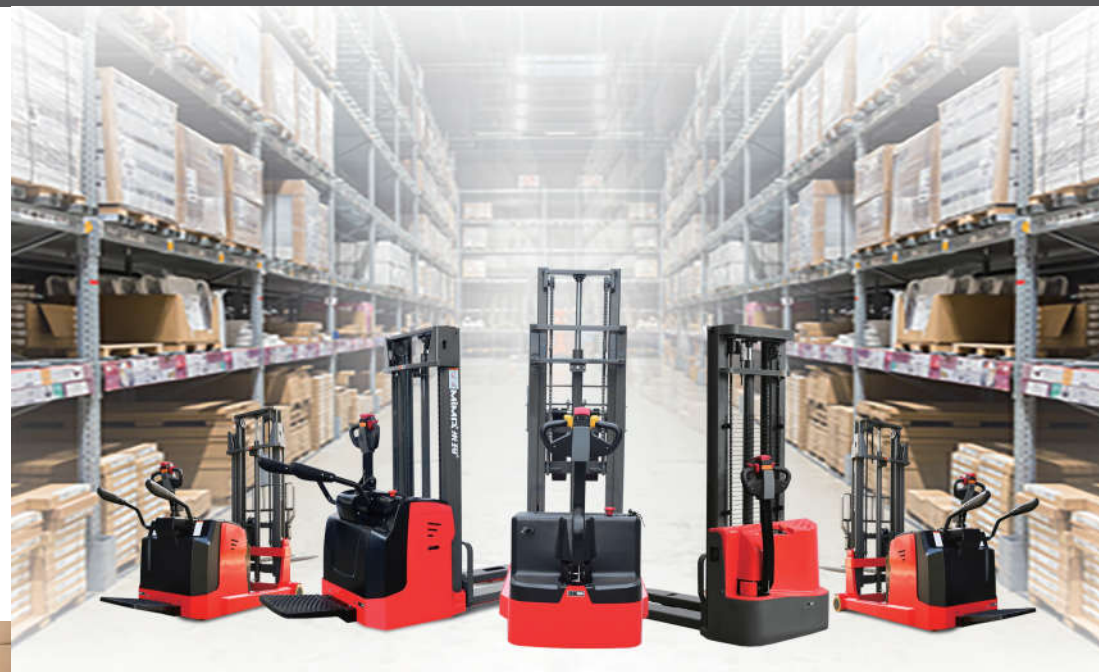

BANYITONG SCIENCE & TECHNOLOGY DEVELOPING CO.,LTD.

Add: Crossing of Daihe Road and Cailun Road,Hefei,China  
Tel: +86 551 6425 5078  
Fax: +86 551 6211 3877  
E-mail: sales@mimachina.com  
Website: www.mimaforklift.com



Website

## ELECTRIC PALLET STACKER

MB/MBB/MBC/MBD Series

**MiMA**<sup>®</sup>

BANYITONG SCIENCE & TECHNOLOGY DEVELOPING CO.,LTD.

[www.mimaforklift.com](http://www.mimaforklift.com)



# MB15/20

## ELECTRIC PALLET STACKER

MB15/20 is an electric pallet stacker with rated load of 1500kg/2000kg. It is mainly suitable for horizontal transportation on flat ground or in containers.

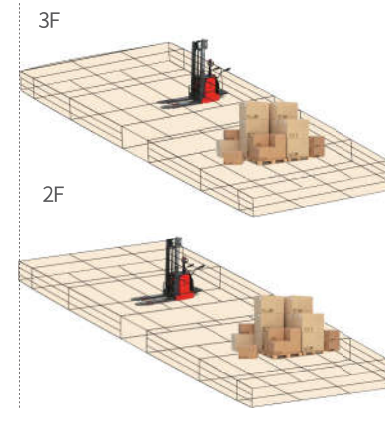

## PRODUCT FEATURES



- The multi-function display instrument has power display, fault code display, working hours display and fast and slow speed display
- Emergency power off button, which can be used in an emergency, more secure
- Using the latest imported AC system is beneficial for users to control accurately and improve efficiency

- The whole system adopts imported waterproof connectors, and all wires and cables have reliable protection, which greatly improve the reliability of the electrical system
- Due to the function of drop buffer, it is effective to keep cargo safe
- The vertical drive makes the turning radius of the entire drive unit small, the wheel replacement and maintenance are simple, and the motor has better effects of dust-proof and waterproof, making the driver and motor more durable and reliable



- All operations can be easily completed with one hand, because of the simple and beautiful integrated handle
- The handle is equipped with an emergency reverse switch, so the operation of the whole vehicle is safer
- The handle is braked in both vertical and horizontal directions to improve the safety of the model
- The stand on model will reduce speed automatically with steering angle becoming larger

- Low center of gravity design with good stability
- Sturdy mast



Standard						
1.1 Brand		MIMA	MIMA	MIMA	MIMA	MIMA
1.2 Model		MB1530 (Single cylinder)	MB2030 (Single cylinder)	MB1530 (Double cylinder)	MB2030 (Double cylinder)	MB1545 (Double cylinder)
1.3 Power type		Battery	Battery	Battery	Battery	Battery
1.4 Operation type		Stand on	Stand on	Stand on	Stand on	Stand on
1.5 Rated capacity	Q(kg)	1500	2000	1500	2000	1500
1.6 Load center	C(mm)	600	600	600	600	600
1.7 Front overhang	x(mm)	737	737	722	722	712
1.8 Wheelbase	y(mm)	1390	1390	1390	1390	1390
Weight						
2.1 Service weight(incl. battery)		1100	1115	1270	1300	1450
2.2 Axle capacity with full load, drive side/load side		1052/1548	1149/1966	1166/1604	1266/2034	1297/1653
2.3 Axle capacity with no load, drive side/load side		795/305	807/308	926/344	947/353	1057/393
1079/401						
Wheel						
3.1 Wheel type		PU	PU	PU	PU	PU
3.2 Load wheel	mm	Φ80×70	Φ80×70	Φ80×70	Φ80×70	Φ80×70
3.3 Drive wheel	mm	Φ230×75	Φ230×75	Φ230×75	Φ230×75	Φ230×75
3.4 Auxiliary wheel	mm	Φ125×50	Φ125×50	Φ125×50	Φ125×50	Φ125×50
3.5 Number of wheels, front/rear(x=drive wheel)		4/1x+2	4/1x+2	4/1x+2	4/1x+2	4/1x+2
3.6 Wheel tread, drive side	b10(mm)	630/770	630/770	630/770	630/770	630/770
3.7 Wheel tread, load side	b11(mm)	490/380	490/380	490/380	490/380	490/380
Size						
4.1 Mast closed height	h1(mm)	2025	2025	2025	2025	2100
4.2 Free lift height	h2(mm)	/	/	/	/	/
4.3 Lift height	h3(mm)	3000	3000	3000	3000	4500
4.4 Mast extended height with load-backrest	h4(mm)	3506	3506	3490	3490	5076
4.5 Handle height	h14(mm)	1100/1390	1100/1390	1100/1390	1100/1390	1100/1390
4.6 Fork face min. ground clearance	h13(mm)	90	90	90	90	90
4.7 Overall length, pedal off	l1(mm)	2110	2110	2130	2130	2130
4.8 Overall width	b1(mm)	850/1000	850/1000	850/1000	850/1000	850/1000
4.9 Fork size	l/s(mm)	1150/190/56	1150/190/56	1150/190/56	1150/190/56	1150/190/56
4.10 Fork outside width	b5(mm)	680/570	680/570	680/570	680/570	680/570
4.11 Mast ground clearance	m1(mm)	30	30	30	30	30
4.13 Aisle width for pallet 1000*1200mm(C=500mm) pedal off	Ast(mm)	2490	2490	2490	2490	2490
4.14 Aisle width for pallet 800*1200mm(C=600mm) pedal off	Ast(mm)	2450	2450	2450	2450	2450
4.15 Turning radius	Wa(mm)	1655	1655	1655	1655	1655
Function						
5.1 Driving speed(load/unload)	km/h	5.0/6.0	5.0/6.0	5.0/6.0	5.0/6.0	5.0/6.0
5.2 Lifting speed(load/unload)	mm/s	90/130	65/115	125/175	65/100	90/130
5.3 Lowering speed(load/unload)	mm/s	110/130	85/115	115/135	95/100	95/100
5.4 Max. gradeability(load/unload)(S2-5min)	%(tanθ)	≤6/≤10	≤6/≤8	≤8/≤10	≤6/≤8	≤8/≤10
5.5 Brake type		Electromagnetic	Electromagnetic	Electromagnetic	Electromagnetic	Electromagnetic
Drive						
6.1 Driving motor(S2-60min)	kw	1.5	1.5	1.5	1.5	1.5
6.2 Lifting motor(S3-15%)	kw	2	2	2	2	3
6.3 Battery voltage/capacity	V/Ah	24/210	24/210	24/210	24/210	24/210
6.4 Battery weight	kg	200	200	200	200	200
6.5 Steering system		EPS	EPS	EPS	EPS	EPS
Other						
7.1 Battery replacement type		Side pull	Side pull	Side pull	Side pull	Side pull
7.2 Mast type		Duplex mast	Duplex mast	Duplex mast	Duplex mast	Triplex mast

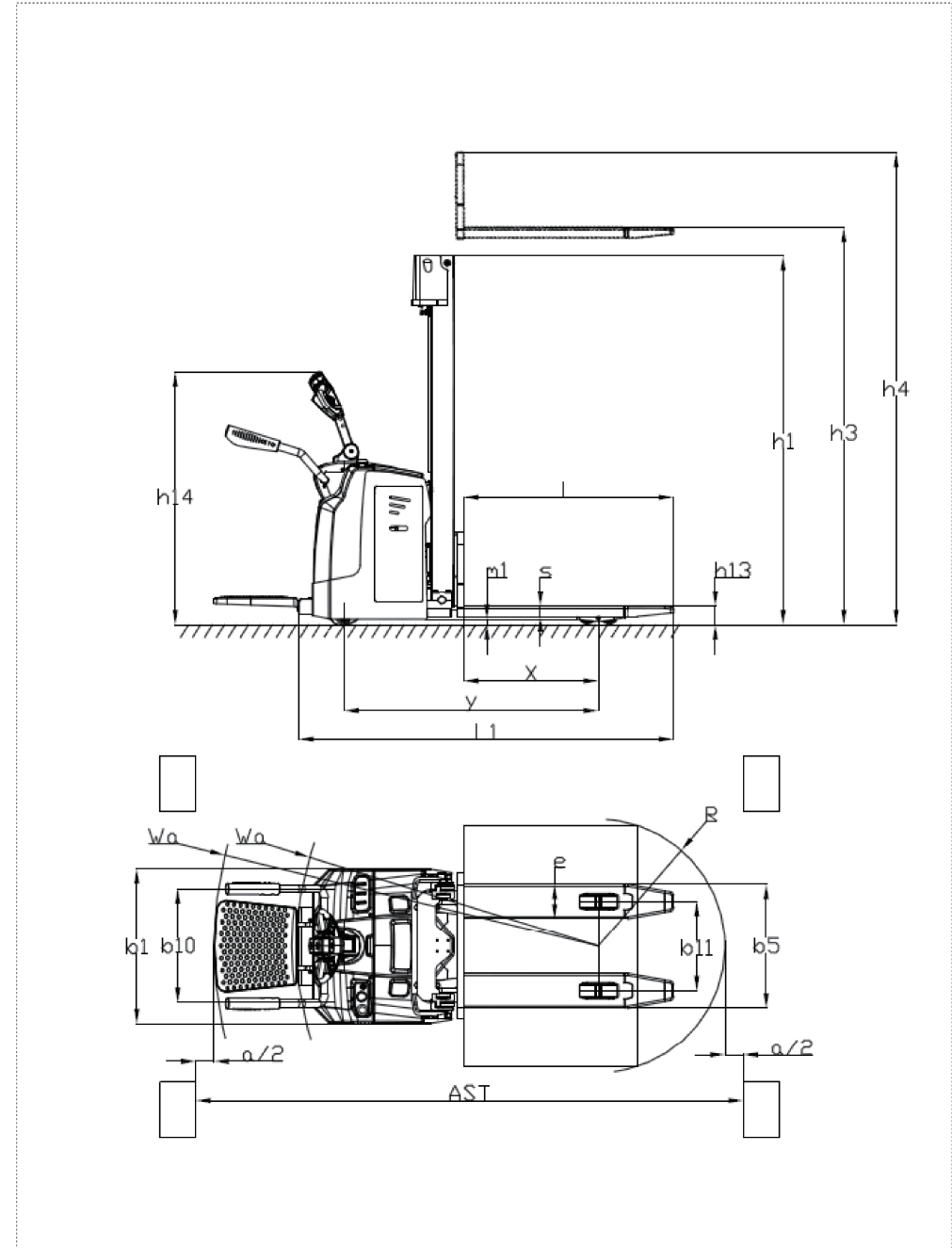

Single mast		MB15/MB20 series	
Model		MB1516	MB2016
Mast type		Single mast	
Mast closed height	h1	mm	2090
Mast extended height	h4	mm	2090
Free lift height	h2	mm	1600

Single cylinder duplex mast		MB15/MB20 series					
Model		MB1525 MB2025	MB1530 MB2030	MB1535 MB2035	MB1540 MB2040	MB1545 MB2045	
Mast type		Duplex mast	Duplex mast	Duplex mast	Duplex mast	Duplex mast	
Mast closed height	h1	mm	1775	2025	2275	2575	2825
Mast extended height	h4	mm	3006	3506	4006	4556	5056

Double cylinders duplex mast		MB15/MB20 series					
Model		MB1525 MB2025	MB1530 MB2030	MB1535 MB2035	MB1540 MB2040	MB1545 MB2045	
Mast closed height	h1	mm	1775	2025	2275	2575	2825
Mast extended height	h4	mm	3020	3520	4020	4570	5070

Triplex mast		MB15/MB20 series				
Model		MB1535 MB2035	MB1540 MB2040	MB1545 MB2045	MB1550 MB2050	
Mast closed height	h1	mm	1766	1933	2100	2267
Mast extended height	h4	mm	4000	4500	5000	5500

Load chart

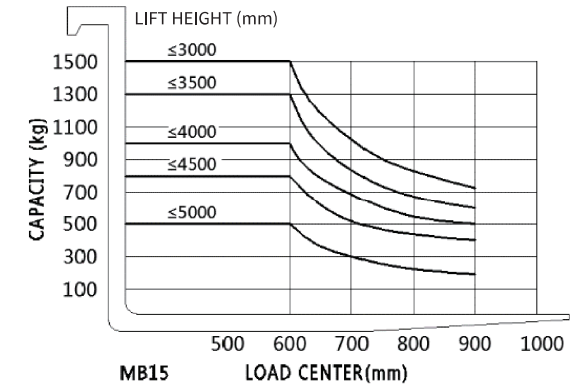

Load chart

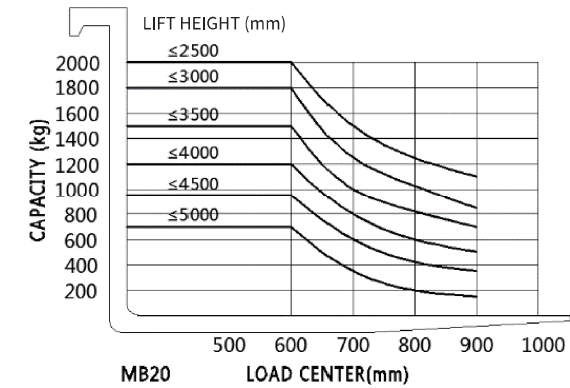

## **MBD12/15** ELECTRIC PALLET STACKER

MBD12 / 15 is an electric pallet stacker with rated capacity of 1200kg / 1500kg with smart design and flexible reaction. It can also perform efficiently and safely in limited space.



## PRODUCT FEATURES



- Ergonomic, compact design with long handle
- Emergency reverse driving function to protect driver safety

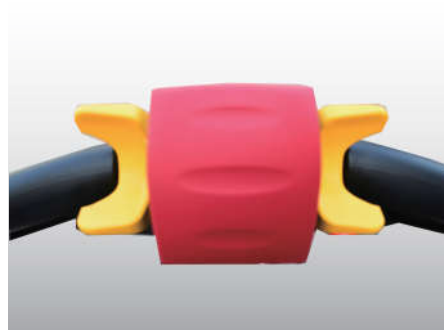

- H-shaped hot-rolled mast channel steel and strong mast make the vehicle have better stability and longer service life
- The mechanical structure material is solid, and key parts are made of high strength steel plate, which is strong and durable



- With smaller turning radius
- Low center of gravity design, good stability of the model
- Exquisite structure, excellent details, easy assembly and disassembly, easy maintenance
- Maintenance-free battery is easier on maintaining

- The drive mechanism adopts the vertical structure drive unit, the entire drive unit has a small turning radius, low running noise, and convenient replacement and maintenance of model
- The most advanced permanent magnet brushless drive motor used in this model is carbon-free, maintenance-free, has a good regenerative braking function and ramp suppression function, and has excellent driving control



Standard				
1.1	Brand	MIMA	MIMA	
1.2	Model	MBD12	MBD15	
1.3	Power type	Battery	Battery	
1.4	Operation type	Walking	Walking	
1.5	Rated capacity	Q(kg)	1200	1500
1.6	Load center	C(mm)	500	500
1.7	Wheelbase	y(mm)	1200	1200
Weight				
2.1	Service weight(incl. battery)		560	590
2.2	Axle capacity with full load, drive side/load side		/	/
2.3	Axle capacity with no load, drive side/load side		/	/
Wheel				
3.1	Wheel type		PU	PU
3.2	Load wheel	mm	Φ80×70	Φ80×70
3.3	Drive wheel	mm	Φ210×70	Φ210×70
3.4	Auxiliary wheel	mm	Φ125×50	Φ125×50
3.5	Number of wheels, front/rear(≠drive wheel)		2/1x*1	2/1x*1
3.6	Wheel tread, drive side	b10(mm)	/	/
3.7	Wheel tread, load side	b11(mm)	400	400
Size				
4.1	Mast closed height	h1(mm)	Refer to the mast specification	Refer to the mast specification
4.2	Lift height	h3(mm)	Refer to the mast specification	Refer to the mast specification
4.3	Mast extended height with load-backrest	h4(mm)	Refer to the mast specification	Refer to the mast specification
4.4	Handle height	h14(mm)	800/1200	800/1200
4.5	Fork face min. ground clearance	h13(mm)	85	85
4.6	Overall length, pedal on/off	l1(mm)	1750	1750
4.7	Overall width	b1(mm)	800	800
4.8	Fork size	l/e/s(mm)	1150/160/60	1150/160/60
4.9	Fork outside width	b5(mm)	560	560
4.10	Mast ground clearance	m1(mm)	30	30
4.11	Aisle width for pallet 1000*1200mm (C=500mm)	Ast(mm)	2050	2050
4.12	Aisle width for pallet 800*1200mm (C=600mm)	Ast(mm)	2100	2100
4.13	Turning radius	Wa(mm)	1440	1440
Function				
5.1	Driving speed(load/unload)	km/h	3.5/4	3.5/3.6
5.2	Lifting speed(load/unload)	mm/s	110/180	73/107
5.3	Lowering speed(load/unload)	mm/s	130/160	85/115
5.4	Max. gradeability(load/unload)(S2-5min)	%(tanθ)	3/6	3/6
5.5	Brake type		Electromagnetic	Electromagnetic
Drive				
6.1	Driving motor(S2-60min)	kw	0.75	0.75
6.2	Lifting motor(S3-15%)	kw	2	2
6.3	Battery voltage/capacity	V/Ah	2×12/80*	2×12/80*
6.4	Battery weight	kg	50	50
6.5	Steering System		Mechanical steering	Mechanical steering
Other				
7.1	Battery type		Battery	Battery
7.2	Mast type		Single cylinder and duplex mast	Single cylinder and duplex mast
7.3	Lithium battery voltage / capacity	V/Ah	24/80	24/80

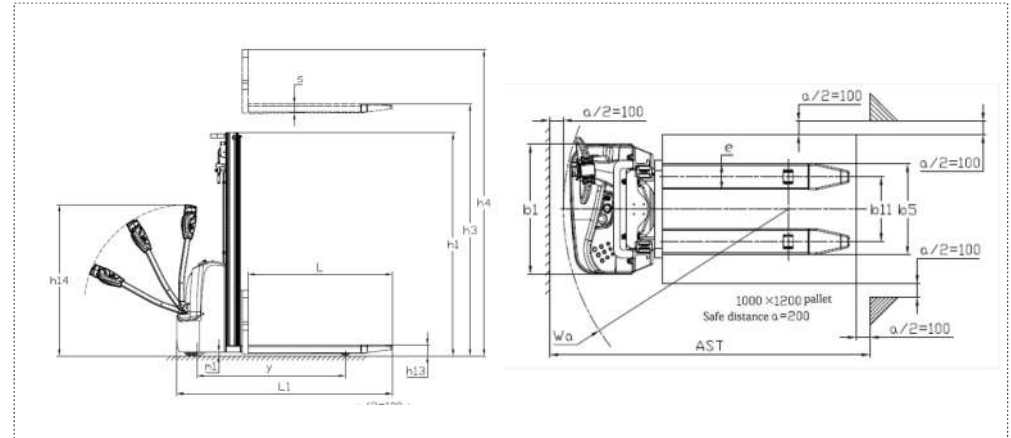

MBD12 Single cylinder and duplex mast				
Model		MBD1225	MBD1230	
Mast closed height	h1	mm	1780	2030
Mast extended height	h4	mm	3010	3510
MBD15 Single cylinder and duplex mast				
Model		MBD1525	MBD1530	
Mast closed height	h1	mm	1780	2030
Mast extended height	h4	mm	3010	3510

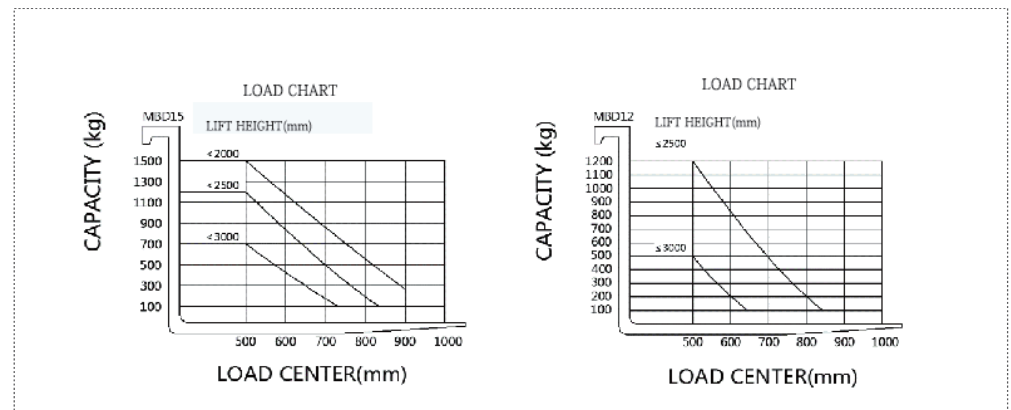





# MBB09

## ELECTRIC COUNTERBALANCED STACKER

MBB09 is an electric counterbalanced stacker with rated capacity 900kg and lifting height 3000mm, with compact size and light weight. It is suitable for narrow aisle operation, such as, floor, elevator etc. Without fork led design, suitable for open pallet and closed pallet.



## PRODUCT FEATURES

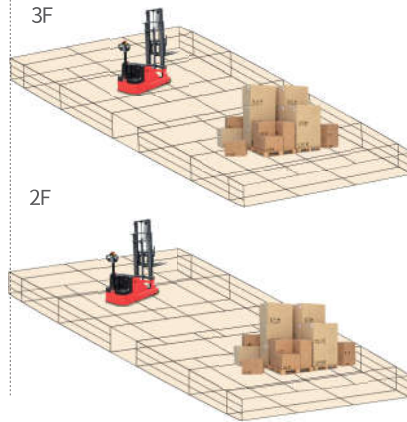

- With folded sleeve fork, easy to enter into the elevator, suitable for second floor working, need smaller turning radius and aisle.



- American Curtis controller, AMP waterproof and dustproof plug-in, which provides reliable protection of the circuit and greatly reduces electrical failures
- Maintenance-free battery with super endurance, easy to use, built-in charger, more convenient to charge;
- Exquisite structure, excellent details, easy assembly and disassembly,



- Ergonomic design of operation handle , simple and beautiful.Integrated handle make operation easier, all the function are independent, can operate by one hand
- The handle lever is equipped with an emergency reverse switch, which makes the operation safer
- The handle is in the braking state in both vertical and horizontal directions, improving the safety



- Multi-function instrument is with battery power , fault code ,hour meter, speed(fast or slow) display
- Emergency power off button, which can be used in emergency situations, more secure
- Adopts latest imported AC control system which is more accurate and efficient

Standard					
1.1 Brand		MIMA	MiMA	MIMA	MIMA
1.2 Model		MBB0916	MBB0920	MBB0925	MBB0930
1.3 Power type		Battery	Battery	Battery	Battery
1.4 Operation type		Walkie	Walkie	Walkie	Walkie
1.5 Rated capacity	Q(kg)	900	900	900	900
1.6 Load center	C(mm)	400	400	400	400
1.7 Front overhang	x(mm)	80	80	80	80
1.8 Wheelbase	y(mm)	1150	1150	1150	1150
Weight					
2.1 Service weight(incl. battery)	kg	1100	1140	1160	1180
2.2 Axle capacity with no load, drive side/load side	kg	600/500	600/540	600/560	600/580
2.3 Axle capacity with full load, drive side/load side	kg	220/1780	224/1816	227/1833	230/1850
Wheel					
3.1 Wheel type		PU	PU	PU	PU
3.2 Load wheel	mm	φ140x100	φ140x100	φ140x100	φ140x100
3.3 Drive wheel	mm	φ210x70	φ210x70	φ210x70	φ210x70
3.4 Number of wheels, front/rear(x=drive wheel)		2/1x	2/1x	2/1x	2/1x
3.5 Wheel tread, load side	b11(mm)	775	775	775	775
Size					
4.1 Mast closed height	h1(mm)	2100	1495	1745	1995
4.2 Free lift height	h2(mm)	1600	/	/	/
4.3 Lift height	h3(mm)	1600	2000	2500	3000
4.4 Mast extended height with load-backrest	h4(mm)	2200	2600	3100	3600
4.5 Overall length	L1(mm)	2235	2235	2235	2235
4.6 Overall width	b1/b2(mm)	700/875	700/875	700/875	700/875
4.7 Fork size	l/e/s(mm)	850/100/35	850/100/35	850/100/35	850/100/35
4.8 Fork-carriage width	b3(mm)	650	650	650	650
4.9 Fork outside width	b5(mm)	220-600	220-600	220-600	220-600
4.10 Inner leg width	b4(mm)	625	625	625	625
4.11 Handle height	h14(mm)	820-1150	820-1150	820-1150	820-1150
4.12 Mast ground clearance	(mm)	50	50	50	50
4.13 Aisle width for pallet 1000*1200mm	Ast(mm)	2740	2740	2740	2740
4.14 Aisle width for pallet 800*1200mm	Ast(mm)	2850	2850	2850	2850
4.15 Turning radius	Wa(mm)	1300	1300	1300	1300
Function					
5.1 Driving speed(load/unload)	km/h	3/3.5	3/3.5	3/3.5	3/3.5
5.2 Lifting speed(load/unload)	mm/s	145/215	145/215	145/215	145/215
5.3 Lowering speed(load/unload)	mm/s	105/105	105/105	105/105	105/105
5.4 Max. gradeability(load/unload)(S2-5min)	%(tanθ)	3/5	3/5	3/5	3/5
5.5 Brake type		Electromagnetic	Electromagnetic	Electromagnetic	Electromagnetic
Drive					
6.1 Driving motor(S2-60min)	kw	0.75	0.75	0.75	0.75
6.2 Lifting motor(S3-15%)	kw	2	2	2	2
6.3 Battery voltage/capacity	V/Ah	24/100	24/100	24/100	24/100
6.4 Battery weight	kg	65	65	65	65
6.5 Steering System		Mechanical	Mechanical	Mechanical	Mechanical

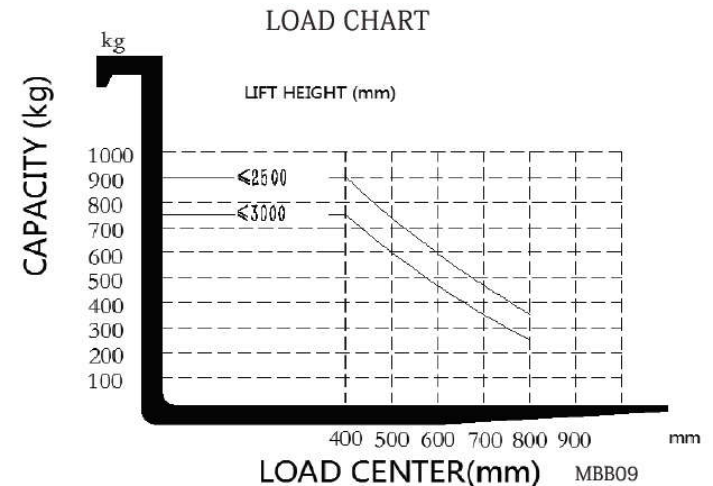
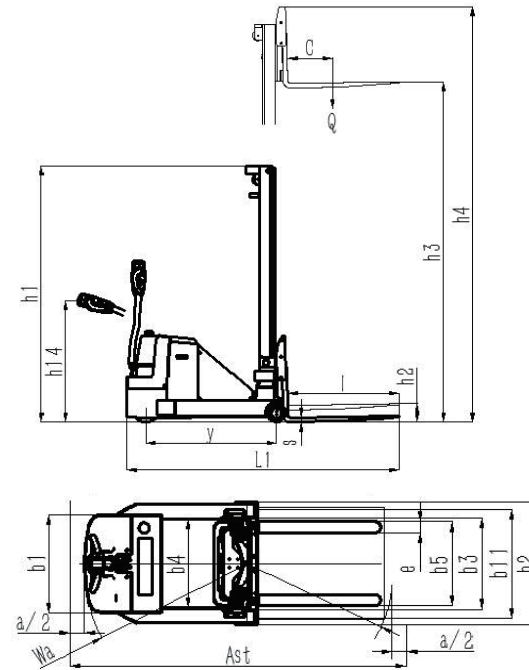

## MBB10/16

### ELECTRIC COUNTERBALANCED STACKER

MBB10/16 is an electric counterbalanced stacker, rated capacity 1000kg/1600kg, and max lifting height 3500mm. With small, beautiful and high cost performance, it is mainly used in flat ground, the second floors and containers.

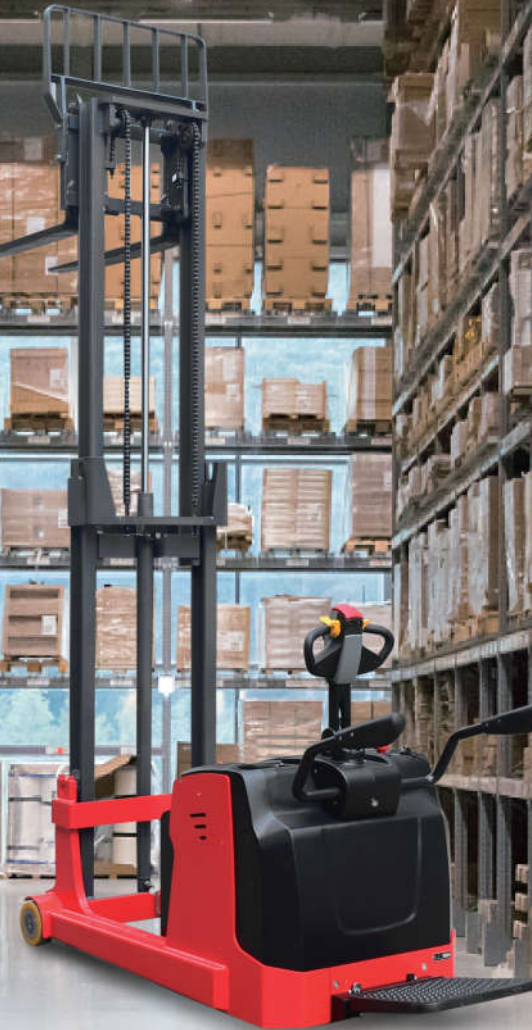

## PRODUCT FEATURES



- Equipped with armrest, with function of slow down when the armrest down.
- With structure of buffer when cylinder lowered, which makes the goods placed more smoothly.



- The five-pivot structure ensures that the body is stable during the load stacking process, not floating;
- Thick bottom plate structure of the body, which effectively reduces the center of gravity, more stable and efficient when handling and stacking
- The mast is made of high-quality alloy H-shaped channel steel with excellent bending and torsion resistance, steady and durable, ensuring the load capacity.



- Standard equipped with electromagnetic brake, handle press brake, emergency stop switch, emergency reverse switch and slope assist function to ensure operator safety
- American Curtis controller can realize stepless speed regulation; AMP waterproof and dustproof plug-in, which provides reliable protection of the circuit and greatly reduces electrical failures
- Maintenance-free AC motor reduce the maintenance cost. After-sales engineers can quickly and accurately read the forklift data through the encoder, shortens the maintenance time.

- The front cover disassemble easily, the electrical components and hydraulic components are arranged centrally, which makes the maintenance easy.



Standard					
1.1 Brand		MIMA	MIMA	MIMA	MIMA
1.2 Model		MBB1016	MBB1025	MBB1030	MBB1035
1.3 Power type		Battery	Battery	Battery	Battery
1.4 Operation type		Stand on	Stand on	Stand on	Stand on
1.5 Rated capacity	Q(kg)	1000	1000	1000	1000
1.6 Load center	C(mm)	500	500	500	500
1.7 Front overhang	x(mm)	100	100	100	100
1.8 Wheelbase	y(mm)	1050	1050	1050	1050
Weight					
2.1 Service weight(incl. battery)	kg	1680	1760	1790	1820
2.2 Axle capacity with no load, drive side/load side	kg	941/739	986/774	1002/788	1019/801
2.3 Axle capacity with full load, drive side/load side	kg	367/2313	378/2382	382/2408	386/2434
Wheel					
3.1 Wheel type		PU	PU	PU	PU
3.2 Load wheel	mm	φ180x100	φ180x100	φ180x100	φ180x100
3.3 Drive wheel	mm	φ230x75	φ230x75	φ230x75	φ230x75
3.4 Number of wheels, front/rear(x=drive wheel)		2/1x+2	2/1x+2	2/1x+2	2/1x+2
3.5 Wheel tread, load side	b11(mm)	894	894	894	894
Size					
4.1 Mast closed height	h1(mm)	2090	1760	2010	2260
4.2 Free lift height	h2(mm)	/	/	/	/
4.3 Lift height	h3(mm)	1600	2500	3000	3500
4.4 Mast extended height with load-backrest	h4(mm)	2500	3400	3900	4400
4.5 Overall length	L1(mm)	2560	2560	2560	2560
4.6 Overall width	b1/b2(mm)	994	994	994	994
4.7 Fork size	l/e/s(mm)	1070/100/35	1070/100/35	1070/100/35	1070/100/35
4.8 Fork carriage width	b3(mm)	/	/	/	/
4.9 Fork outside width	b5(mm)	220-610	220-610	220-610	220-610
4.10 Inner leg width	b4(mm)	/	/	/	/
4.11 Handle height	(mm)	1100/1390	1100/1390	1100/1390	1100/1390
4.12 Mast ground clearance	(mm)	66	66	66	66
4.13 Aisle width for pallet 1000*1200mm,pedal off	Ast(mm)	2770	2770	2770	2770
4.14 Aisle width for pallet 800*1200mm,pedal off	Ast(mm)	2880	2880	2880	2880
4.15 Turning radius	Wa(mm)	1415	1415	1415	1415
Function					
5.1 Driving speed(load/unload)	km/h	4/5.8	4/5.8	4/5.8	4/5.8
5.2 Lifting speed(load/unload)	mm/s	80/110	80/110	80/110	80/110
5.3 Lowering speed(load/unload)	mm/s	120/140	120/140	120/140	120/140
5.4 Max. gradeability(load/unload)(S2-5min)	%(tanθ)	5/8	5/8	5/8	5/8
5.5 Brake type		Electromagnetic	Electromagnetic	Electromagnetic	Electromagnetic
Drive					
6.1 Driving motor(S2-60min)	kw	1.5	1.5	1.5	1.5
6.2 Lifting motor(S3-15%)	kw	2	2	2	2
6.3 Battery voltage/capacity	V/Ah	24/210	24/210	24/210	24/210
6.4 Battery weight	kg	200	200	200	200
6.5 Steering system		EPS	EPS	EPS	EPS

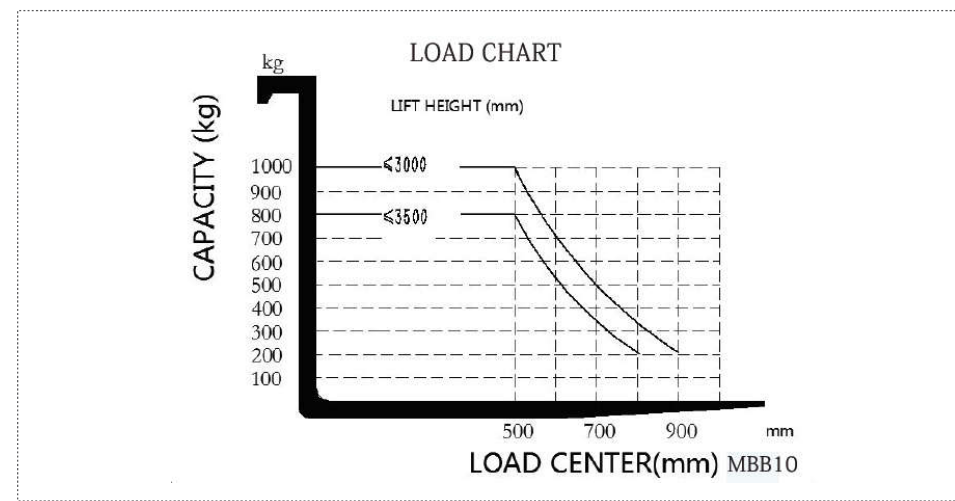
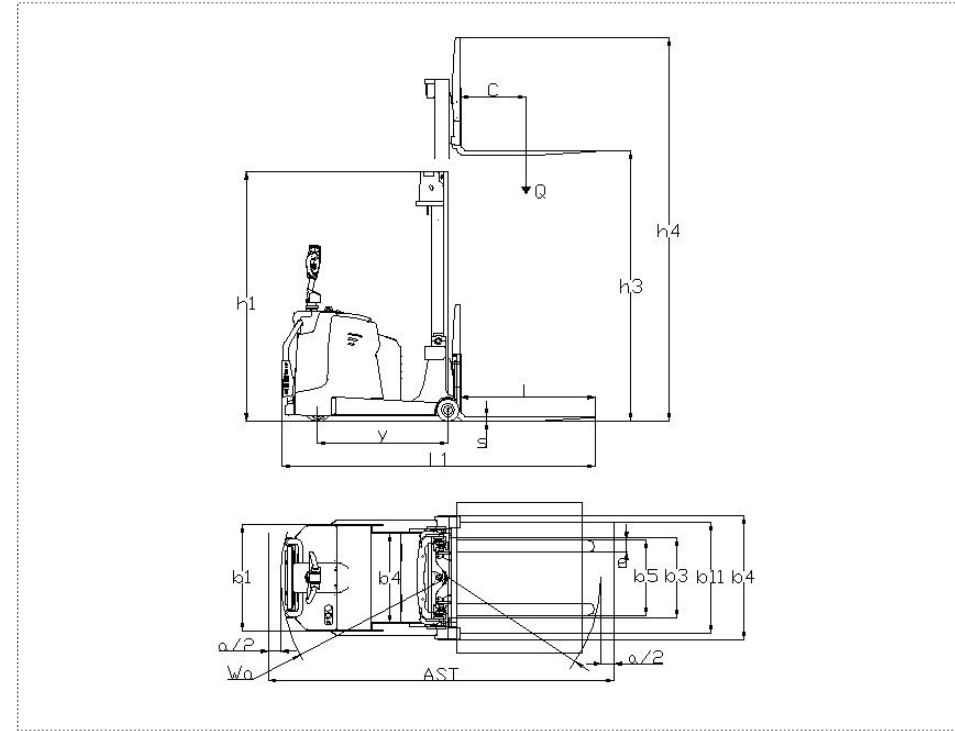

Standard			
1.1	Brand	MIMA	MIMA
1.2	Model	MBB16(Single cylinder duplex mast)	MBB16(Triplex full free mast)
1.3	Power type	Battery	Battery
1.4	Operation type	Stand on	Stand on
1.5	Rated capacity	Q(kg)	1600
1.6	Load center	C(mm)	500
1.7	Wheelbase	y(mm)	1250
Weight			
2.1	Service weight(incl. battery)	kg	2300
2500			
Wheel			
3.1	Wheel type	PU	PU
3.2	Load wheel	mm	φ210×85
3.3	Drive wheel	mm	φ230×75
3.4	Number of wheels, front/rear(x=drive wheel)		2/1x+2
3.5	Wheel tread, load side	b11(mm)	967
967			
Size			
4.1	Tilting	α/β°	2/5 (Mast tilting)
2/5			2/5 (Fork tilting)
4.2	Mast closed height	h1(mm)	Refer to the mast specification
4.3	Free lift height	h2(mm)	Refer to the mast specification
4.4	Lift height	h3(mm)	Refer to the mast specification
4.5	Mast extended height with load-backrest	h4(mm)	Refer to the mast specification
4.6	Overall length	L1(mm)	2765*
2765*			2765*
4.7	Overall width	b1/b2(mm)	900/1060
900/1060			900/1100
4.8	Fork size	l/e/s(mm)	1070/100/35
1070/100/35			1070/100/35
4.10	Fork outside width	b5(mm)	220-710
220-710			220-710
4.11	Handle height	(mm)	1025/1445
1025/1445			1025/1445
4.12	Mast ground clearance	(mm)	70
70			70
4.13	Aisle width for pallet 1000*1200mm pedal off	Ast(mm)	2950*
2950*			2950*
4.14	Aisle width for pallet 800*1200mm pedal off	Ast(mm)	3070*
3070*			3070*
4.15	Turning radius (pedal off)	Wa(mm)	1590*
1590*			1590*
Function			
5.1	Driving speed(load/unload)	km/h	5.5/6
5.5/6			5.5/6
5.2	Lifting speed(load/unload)	mm/s	100/140
100/140			100/125
5.3	Lowering speed(load/unload)	mm/s	100/95
100/95			100/95
5.4	Max. gradeability(load/unload)(S2-5min)	%(tanθ)	6/10
6/10			6/10
5.5	Brake type		Electromagnetic
Electromagnetic			Electromagnetic
Drive			
6.1	Driving motor(S2-60min)	kw	1.5
1.5			1.5
6.2	Lifting motor(S3-10%)	kw	2
2			3
6.3	Battery voltage/capacity	V/Ah	24/210(Optional270)
24/210(Optional270)			24/210(Optional270)
6.4	Battery weight	kg	185
185			185
6.5	Steering system		EPS
EPS			EPS

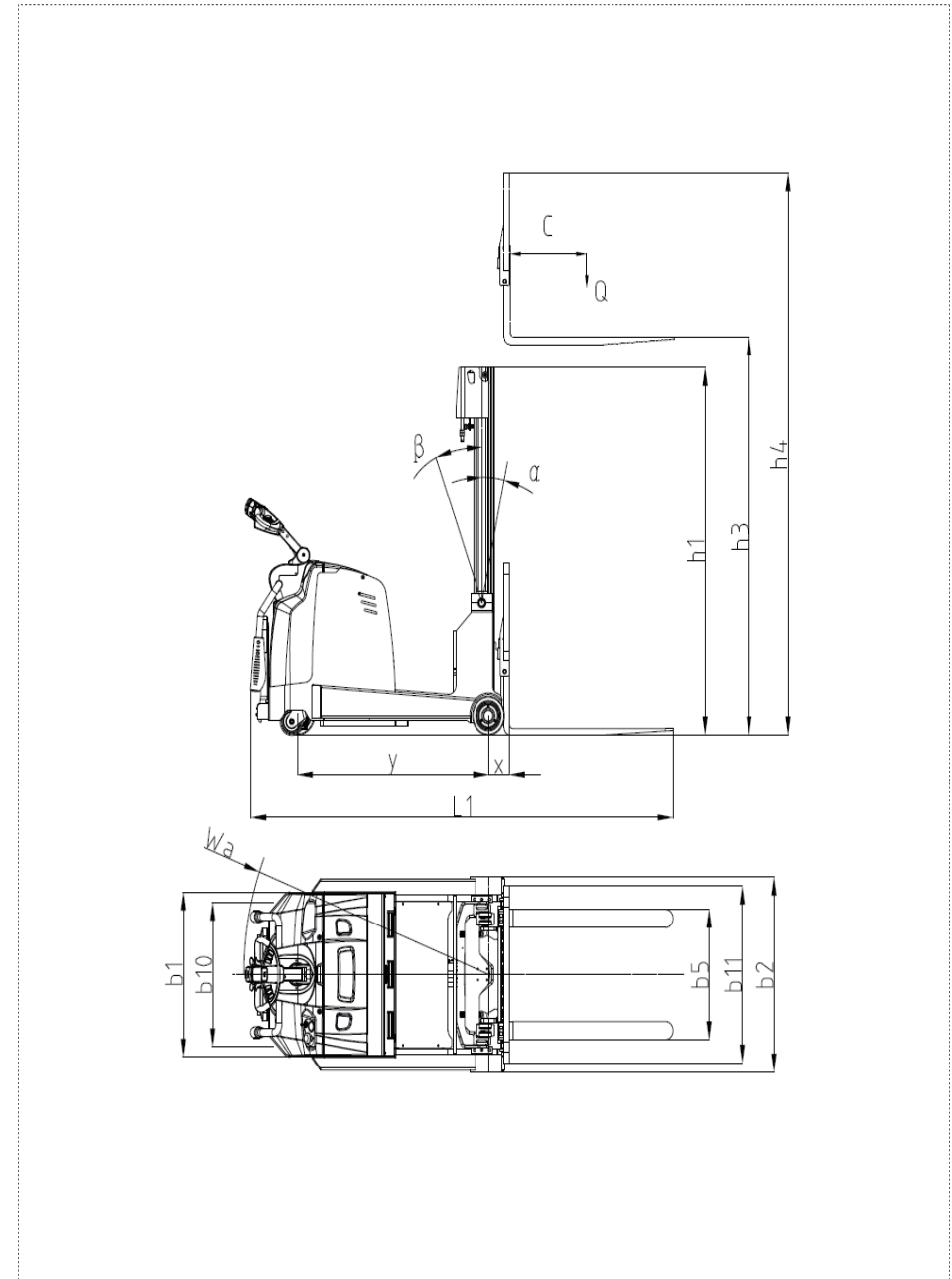

		Single mast		Single cylinder duplex mast			
Model		MBB1616	MBB1625	MBB1630	MBB1635	MBB1640	MBB1645
Lift height	h3 mm	1600	2500	3000	3500	4000	4500
Mast closed height	h1 mm	2090	1760	2010	2260	2560	2810
Mast extended height	h4 mm	2500	3410	3910	4410	4910	5410

Triplex full free mast							
Model		MBB1640	MBB1645	MBB1650	MBB1655		
Lift height	h3 mm	4000	4500	5000	5500		
Mast closed height	h1 mm	1934	2100	2266	2432		
Free lift height	h2 mm	989	1155	1321	1487		
Mast extended height	h4 mm	4935	5435	5935	6435		

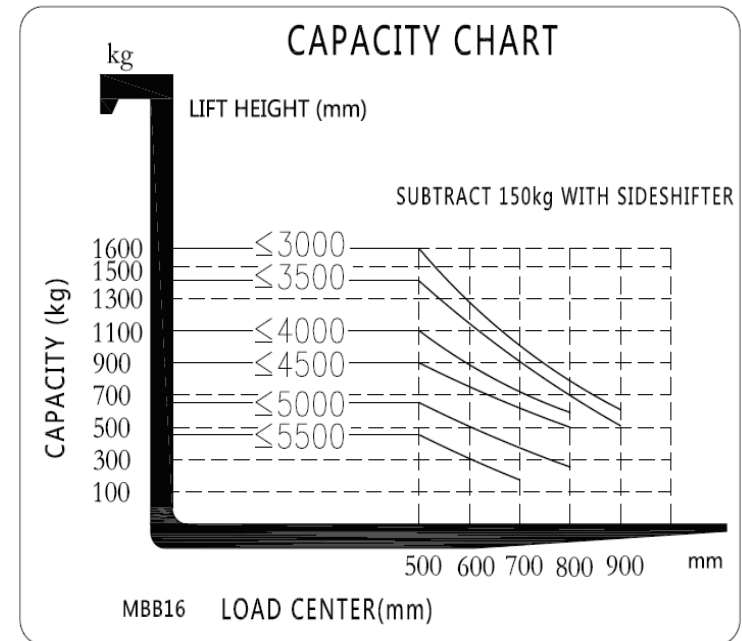



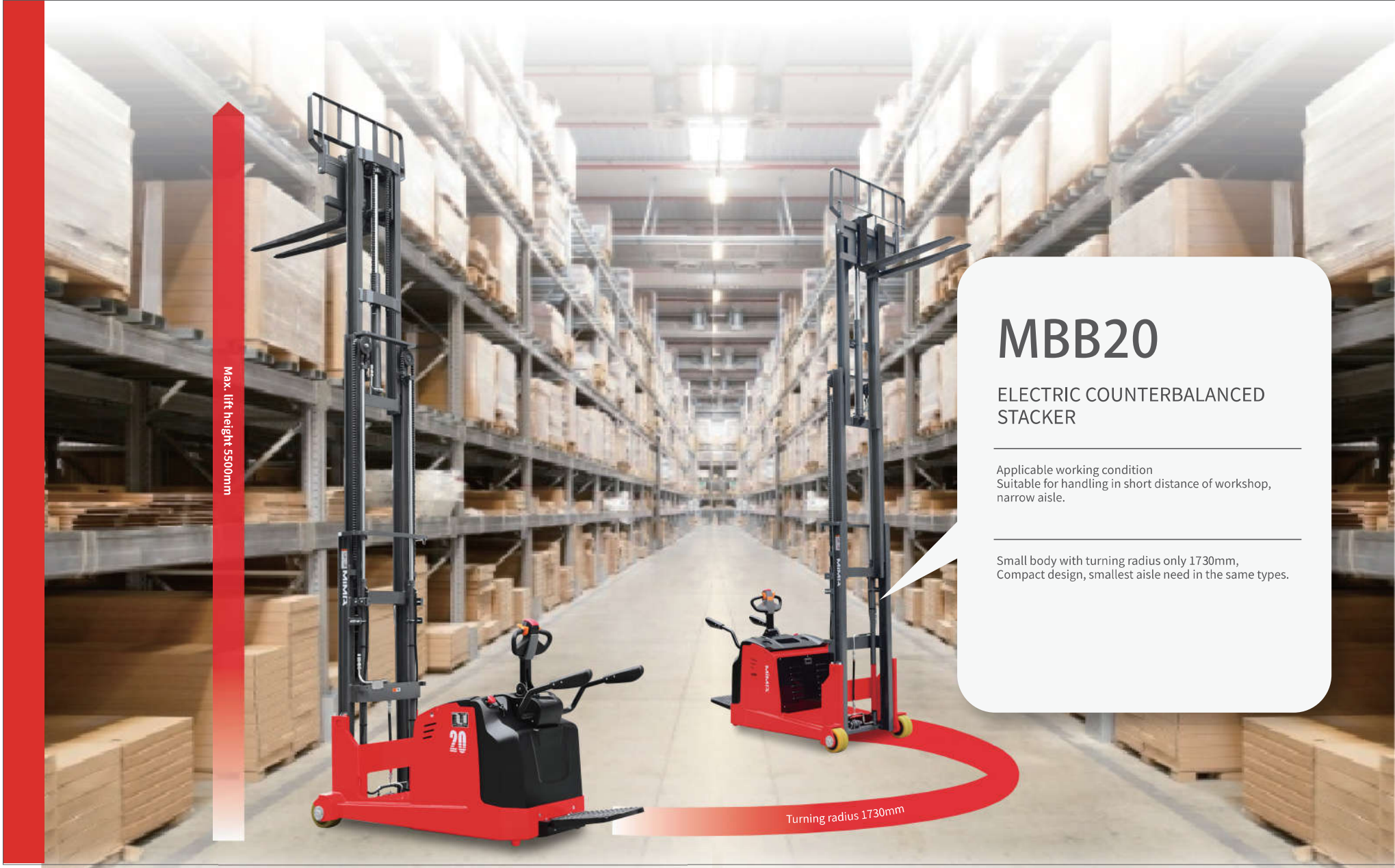

Max. lift height 5500mm

## MBB20

### ELECTRIC COUNTERBALANCED STACKER

Applicable working condition  
Suitable for handling in short distance of workshop,  
narrow aisle.

Small body with turning radius only 1730mm,  
Compact design, smallest aisle need in the same types.

Turning radius 1730mm

## PRODUCT FEATURES

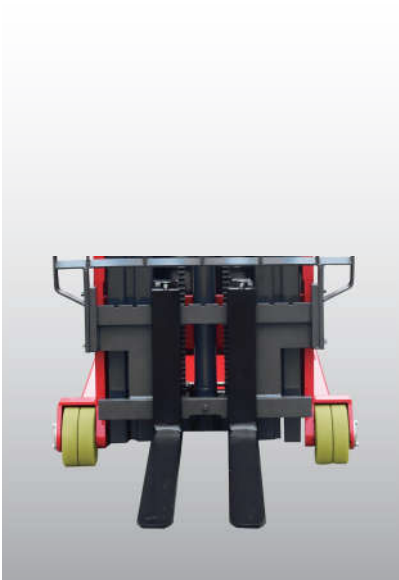

- With smooth and modern shape, multi-curved design of cover, overall forming, wide view mast will let operator enjoy.
- The three-pivot structure ensures that the body is stable during the load stacking process, not floating
- Thick bottom plate structure of the body, which effectively reduces the center of gravity, more stable and efficient when handling and stacking
- The mast is made of high-quality alloy H-shaped channel steel with excellent bending and torsion resistance, steady and durable, ensuring the load capacity.

Driving speed, full load/unload

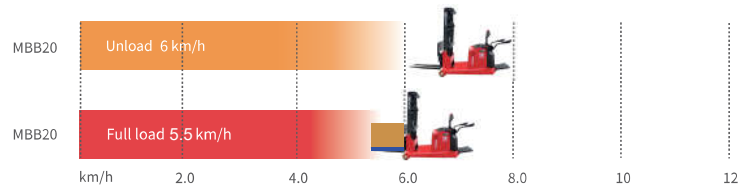

- The maintenance-free AC motor reduce the maintenance cost. After-sales engineers can quickly and accurately read the forklift data through the encoder, shortens the maintenance time.
- The front cover disassemble easily, the electrical components and hydraulic components are arranged centrally, which makes the maintenance easy.



- American Curtis controller can realize stepless speed regulation
- Equiped with armrest, with function of slow down when the armrest down.
- Standard equipped with electromagnetic brake, handle press brake, emergency stop switch, emergency reverse switch and slope assist function to ensure operator safety
- With structure of buffer when cylinder lowered, which makes the goods placed more smoothly

Standard				
1.1	Brand		MIMA	MIMA
1.2	Model		MBE20(Double cylinder duplex mast)	MBB20(Triplex full free mast)
1.3	Power type		Battery	Battery
1.4	Operation type		Stand on	Stand on
1.5	Rated capacity	Q(kg)	2000	2000
1.6	Load center	C(mm)	500	500
1.7	Wheelbase	y(mm)	1450	1450
Weight				
2.1	Service weight(incl. battery)	kg	2550	2750
Wheel				
3.1	Wheel type		PU	PU
3.2	Load wheel	mm	φ210x55	φ210x55
3.3	Drive wheel	mm	φ254x100	φ254x100
3.4	Number of wheels, front/rear(x=drive wheel)		4/1x	4/1x
3.5	Wheel tread, load side	b11(mm)	906	906
Size				
4.1	Tilting	α/β°	2/5(Mast)	2/5(Fork)
4.2	Mast closed height	h1(mm)	Refer to the mast specification	Refer to the mast specification
4.3	Free lift height	h2(mm)	Refer to the mast specification	Refer to the mast specification
4.4	Lift height	h3(mm)	Refer to the mast specification	Refer to the mast specification
4.5	Mast extended height with load-backrest	h4(mm)	Refer to the mast specification	Refer to the mast specification
4.6	Overall length	L1(mm)	2990	2990
4.7	Overall width	b1/b2(mm)	900/1190	900/1190
4.8	Fork size	l/e/s(mm)	1070/122/40	1070/122/40
4.10	Fork outside width	b5(mm)	264-732	264-732
4.11	Handle height	(mm)	1045/1465	1045/1465
4.12	Mast ground clearance	(mm)	80	80
4.13	Aisle width for pallet 1000*1200mm pedal off	Ast(mm)	3150	3150
4.14	Aisle width for pallet 800*1200mm pedal off	Ast(mm)	3270	3270
4.15	Turning radius (pedal off)	Wa(mm)	1730	1730
Function				
5.1	Driving speed(load/unload)	km/h	5.5/6	5.5/6
5.2	Lifting speed(load/unload)	mm/s	100/140	100/125
5.3	Lowering speed(load/unload)	mm/s	100/95	90/95
5.4	Max. gradeability(load/unload)(S2-5min)	%(tanθ)	6/10	6/10
5.5	Brake type		Electromagnetic	Electromagnetic
Drive				
6.1	Driving motor(S2-60min)	kw	2.5	2.5
6.2	Lifting motor(S3-10%)	kw	3	3
6.3	Battery voltage/capacity	V/Ah	24/270(Side pull)	24/270(Side pull)
6.4	Battery weight	kg	235	235
6.5	Steering system		EPS	EPS

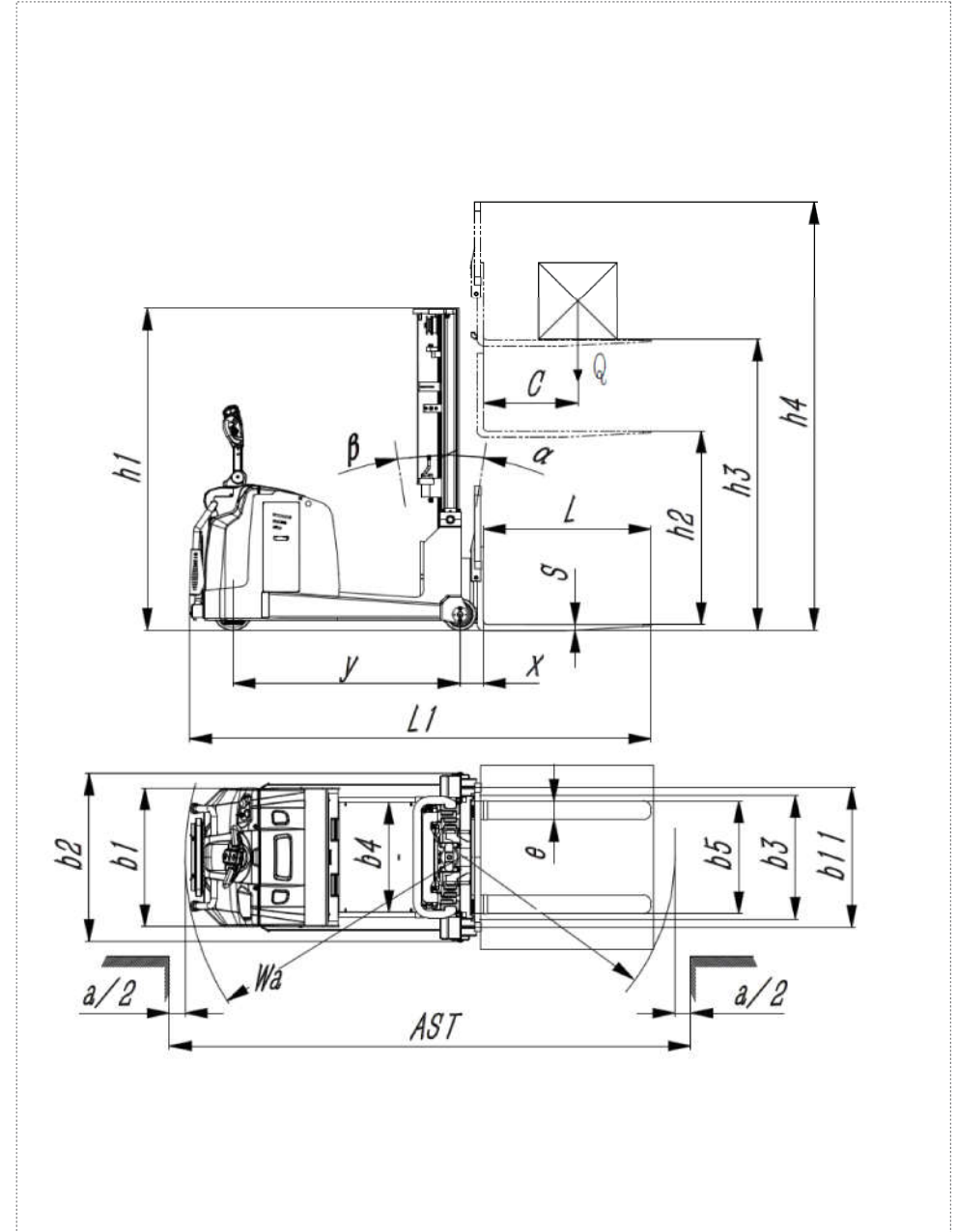

Double cylinder duplex mast

Model	MBB2016 (...single mast...)	MBB2025	MBB2030	MBB2035	MBB2040	MBB2045
Lift height	h3 mm 1600	2500	3000	3500	4000	4500
Mast closed height	h1 mm 2100	1770	2020	2270	2570	2820
Mast extended height	h4 mm 2500	3435	3935	4435	4935	5435

Triplex full free mast

Model	MBB2040	MBB2045	MBB2050	MBB2055
Lift height	h3 mm 4000	4500	5000	5500
Mast closed height	h1 mm 1934	2100	2266	2432
Free lift height	h2 mm 989	1155	1321	1487
Mast extended height	h4 mm 4935	5435	5935	6435

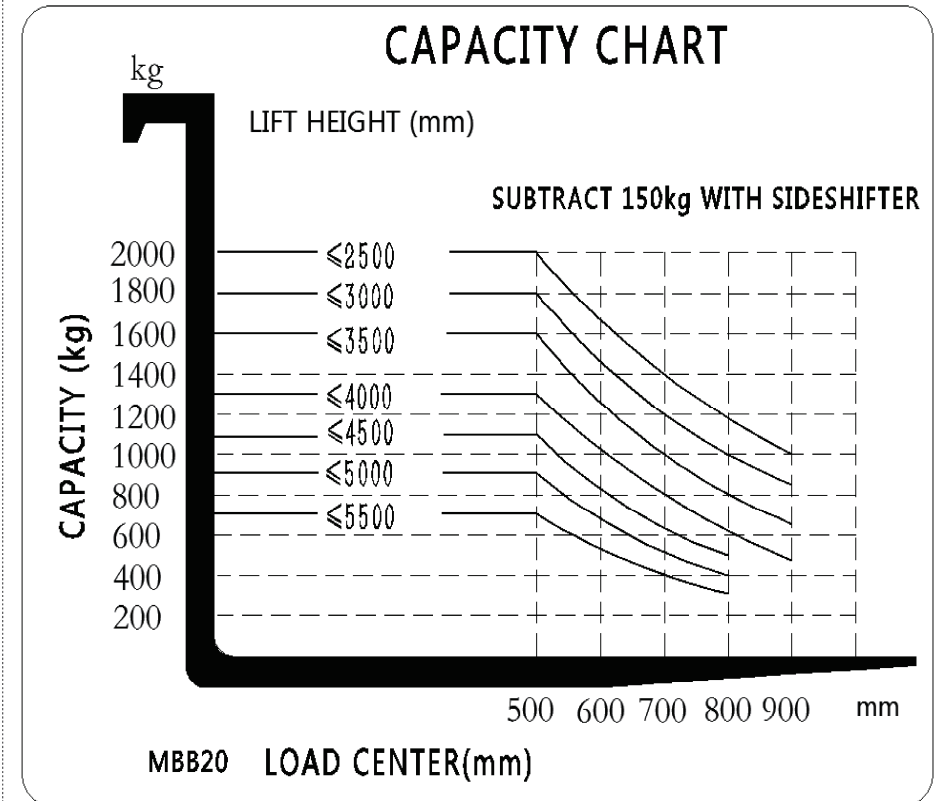



# MBC16/20

## ELECTRIC PALLET STACKER

With 1600&2000kg load capacity, MBC series is walkie type, mainly used in supermarket, warehouse, floor and short-middle distance transportation, it is four fulcrum structure, very stable and economical.

Max. lift height 5000mm

## PRODUCT FEATURES



- With 1490mm very small turning radius, can work smoothly in 2375mm narrow aisle, rear panel is adapted big carved stamping parts, with anti presser foot design, smooth appearance and better anti-collision performance.



- With 30% reduction of energy consumption compared to other forklift, saving charging
- 3 years warranty for 24V lithium battery and 8 years battery life
- With enclosed design, free maintenance
- Fast charging, full charge in 2 hours at the soonest, no need extra battery
- Lithium iron phosphate battery, anti-fire and anti-explosion



- Side pull battery replacement, easy to charge
- USA Curtis controller
- Easy-dismantled covering parts, easy to maintain



- Long handle design, easy to operate, more safe and comfortable. Driver can choose different handle height according to operation habit. Fast and efficient to operate based on safe distance and wide view. With 4 wheel design, very simple for driver to handle pallet.

### BEST CHOICE TO BE USED IN NARROW AISLE



Standard							
1.1 Brand	MIMA	MIMA	MIMA	MIMA	MIMA	MIMA	MIMA
1.2 Model	MBC16 (Single cylinder)	MBC16 (Double Cylinder)	MBC16 (Double Cylinder Triplex Mast)	MBC20 (Single cylinder)	MBC20 (Double Cylinder)	MBC20 (Double Cylinder Triplex Mast)	MBC20 (Double Cylinder Triplex Mast)
1.3 Power type	Battery	Battery	Battery	Battery	Battery	Battery	Battery
1.4 Operation type	Walkie	Walkie	Walkie	Walkie	Walkie	Walkie	Walkie
1.5 Rated capacity	Q(kg)	1600	1600	1600	2000	2000	2000
1.6 Load center	C(mm)	600	600	600	600	600	600
1.7 Wheelbase	y(mm)	1290	1290	1290	1290	1290	1290
Weight							
2.1 Service weight(incl. battery)	kg	1150	1200	1300	1150	1200	1300
Wheel							
3.1 Wheel type	PU	PU	PU	PU	PU	PU	PU
3.2 Load wheel	mm	Φ80×70	Φ80×70	Φ80×70	Φ80×70	Φ80×70	Φ80×70
3.3 Drive wheel	mm	Φ230×75	Φ230×75	Φ230×75	Φ230×75	Φ230×75	Φ230×75
3.4 Auxiliary wheel	mm	Φ125×50	Φ125×50	Φ125×50	Φ125×50	Φ125×50	Φ125×50
3.5 Number of wheels, front/rear(x=drive wheel)		4 /1x+1	4 /1x+1	4 /1x+1	4 /1x+1	4 /1x+1	4 /1x+1
3.6 Wheel tread, drive side	b10(mm)	530	530	530	530	530	530
3.7 Wheel tread, load side	b11(mm)	490	490	490	490	490	490
Size							
4.1 Mast closed height	h1(mm)	Refer to the mast specification	Refer to the mast specification	Refer to the mast specification	Refer to the mast specification	Refer to the mast specification	Refer to the mast specification
4.2 Lift height	h3(mm)	Refer to the mast specification	Refer to the mast specification	Refer to the mast specification	Refer to the mast specification	Refer to the mast specification	Refer to the mast specification
4.3 Mast extended height with load-backrest	h4(mm)	Refer to the mast specification	Refer to the mast specification	Refer to the mast specification	Refer to the mast specification	Refer to the mast specification	Refer to the mast specification
4.4 Handle height	h14(mm)	700/1300	700/1300	700/1300	700/1300	700/1300	700/1300
4.5 Fork face min. ground clearance	h13(mm)	90	90	90	90	90	90
4.6 Overall length	l1(mm)	1990	1990	1990	1990	1990	1990
4.7 Overall width	b1(mm)	820	820	820	820	820	820
4.8 Fork size	l/e/s(mm)	1150/190/58	1150/190/58	1150/190/58	1150/190/58	1150/190/58	1150/190/58
4.9 Fork outside width	b5(mm)	570/680*	570/680*	570/680*	570/680*	570/680*	570/680*
4.10 Min. ground clearance	m1(mm)	30	30	30	30	30	30
4.11 Aisle width for pallet 1000*1200mm	Ast (mm)	2375	2375	2375	2375	2375	2375
4.12 Aisle width for pallet 800*1200mm	Ast (mm)	2375	2375	2375	2375	2375	2375
4.13 Turning radius	Wa (mm)	1490	1490	1490	1490	1490	1490
Function							
5.1 Driving speed(load/unload)	km/h	5.0/6.0	5.0/6.0	5.0/6.0	5.0/6.0	5.0/6.0	5.0/6.0
5.2 Lifting speed(load/unload)	mm/s	90/130	125/175	90/130	90/130	125/175	90/130
5.3 Lowering speed(load/unload)	mm/s	110/130	115/135	95/100	110/130	115/135	95/100
5.4 Max. gradeability(load/unload)(S2-5min)	%(tanθ)	≤6/≤12	≤6/≤12	≤6/≤12	≤6/≤12	≤6/≤12	≤6/≤12
5.5 Brake type		Electromagnetic	Electromagnetic	Electromagnetic	Electromagnetic	Electromagnetic	Electromagnetic
Drive							
6.1 Driving motor(S2-60min)	kw	1.5	1.5	1.5	1.5	1.5	1.5
6.2 Lifting motor(S3-15%)	kw	2	3	3	2	3	3
6.3 Battery voltage/capacity	V/Ah	24/210*	24/210*	24/210*	24/210*	24/210*	24/210*
6.4 Battery weight	kg	180	180	180	180	180	180
6.5 Steering system		Mechanical	Mechanical	Mechanical	Mechanical	Mechanical	Mechanical
Other							
7.1 Battery replacement type		Side pull	Side pull	Side pull	Side pull	Side pull	Side pull
7.2 Mast type		Duplex mast	Duplex mast	Triplex mast	Duplex mast	Duplex mast	Triplex mast
7.3 Lithium battery voltage / capacity	V/Ah	24/150	24/150	24/150	24/150	24/150	24/150

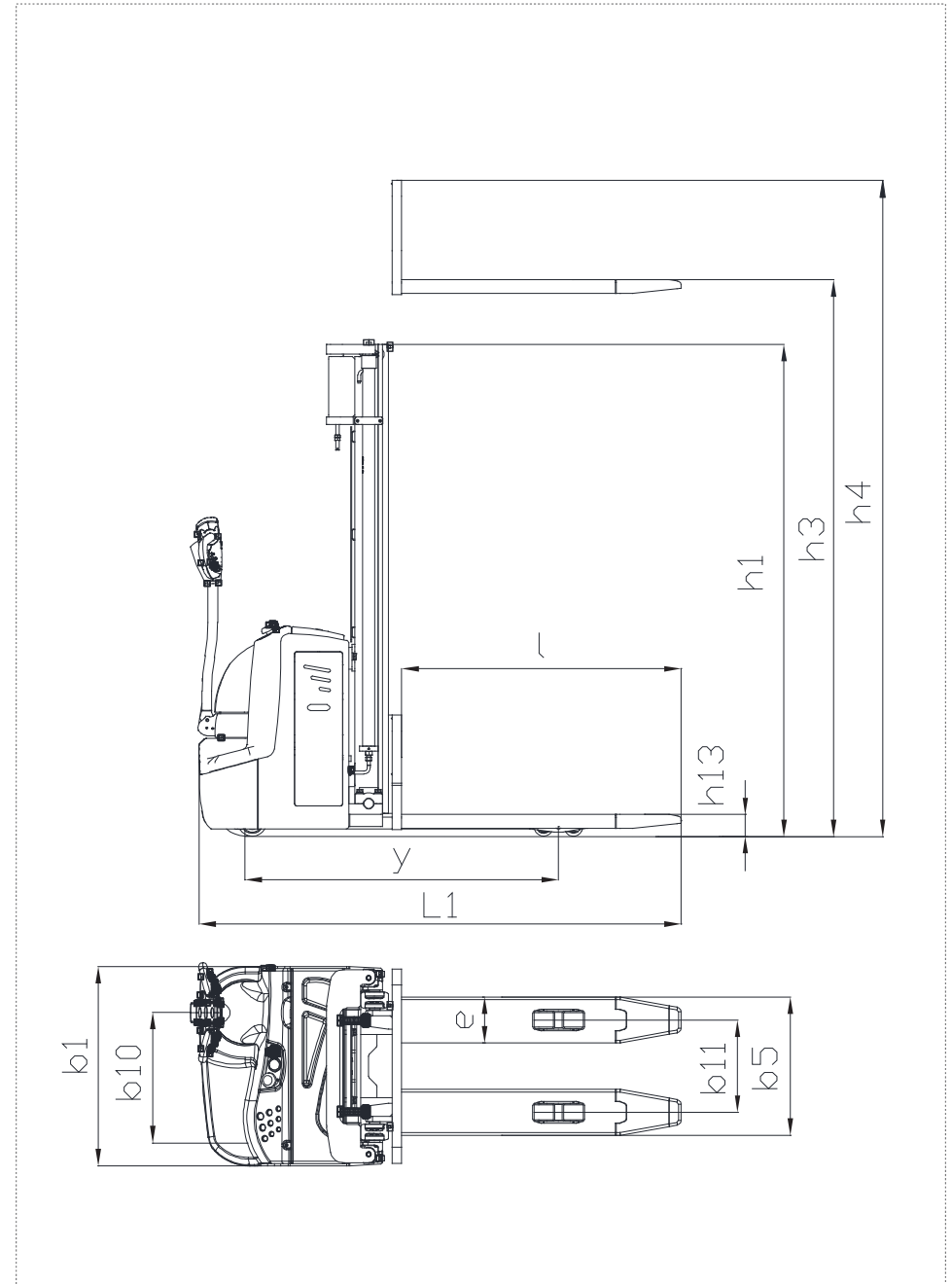

Single mast		MBC16/20		
1.1 Model		MBC1616 MBC2016		
1.2 Mast type		Single mast		
1.3 Lift height	h3	mm	1600	
1.4 Mast closed height	h1	mm	2090	
1.5 Mast extended height	h4	mm	2090	
1.6 Free lift height	h2	mm	1600	

Single cylinder duplex mast		MBC16/20					
1.1 Model		MBC1625	MBC1630	MBC1635	MBC1640	MBC1645	
1.2 Mast type		Duplex mast	Duplex mast	Duplex mast	Duplex mast	Duplex mast	
1.3 Lift height	h3	mm	2500	3000	3500	4000	4500
1.4 Mast closed height	h1	mm	1775	2025	2275	2575	2825
1.5 Mast extended height	h4	mm	3000	3500	4000	4500	5000

Double cylinder duplex mast		MBC16/20					
1.1 Model		MBC1625 MBC2025	MBC1630 MBC2030	MBC1635 MBC2035	MBC1640 MBC2040	MBC1645 MBC2045	
1.2 Lift height	h3	mm	2500	3000	3500	4000	4500
1.3 Mast closed height	h1	mm	1775	2025	2275	2575	2825
1.4 Mast extended height	h4	mm	3000	3500	4000	4500	5000

Triplex mast		MBC16/20			
1.1 Model		MBC1640 MBC2040	MBC1645 MBC2045	MBC1650 MBC2050	
1.2 Lift height	h3	mm	4000	4500	5000
1.3 Mast closed height	h1	mm	1933	2100	2267
1.4 Mast extended height	h4	mm	4500	5000	5500

Triplex full free mast		MBC16/20			
1.1 Model		MBC1640 MBC2040	MBC1645 MBC2045	MBC1650 MBC2050	
1.2 Lift height	h3	mm	4000	4500	5000
1.3 Mast closed height	h1	mm	1933	2100	2267
1.4 Free lift height	h2	mm	1383	1550	1717
1.5 Mast extended height	h4	mm	4500	5000	5500

LOAD CHART

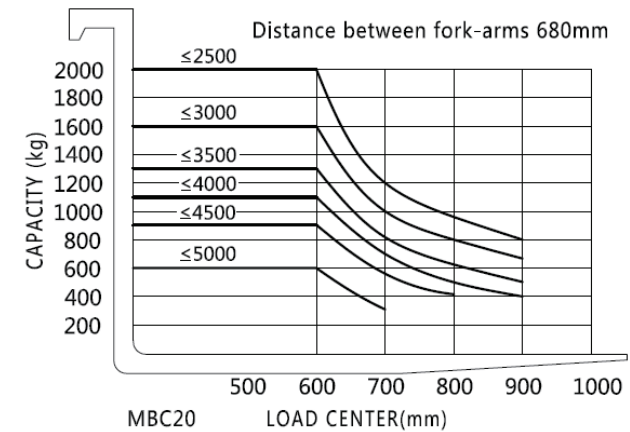
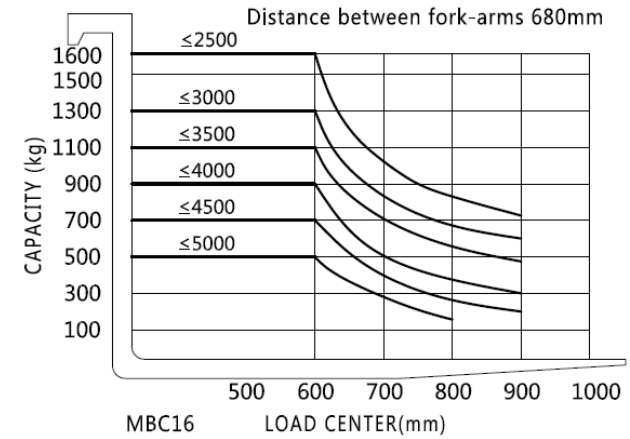

Notes:

- Above load chart is based on 680mm forks outside width ;
- With 570mm forks outside width , MBC16 can load 1600kg within 2500mm lifting height, but has 150kg capacity loss from 2500mm lifting height base on standard load chart;
- With 570mm forks outside width , MBC20 has 200kg capacity loss from 1600mm lifting height based on standard load chart;
- In order to guarantee a better loading performance, customized straddle legs design is available with 570mm forks outside width .